

Lecture 5

Linear Momentum and Collisions

Elastic Properties of Solids



Linear Momentum and Collisions

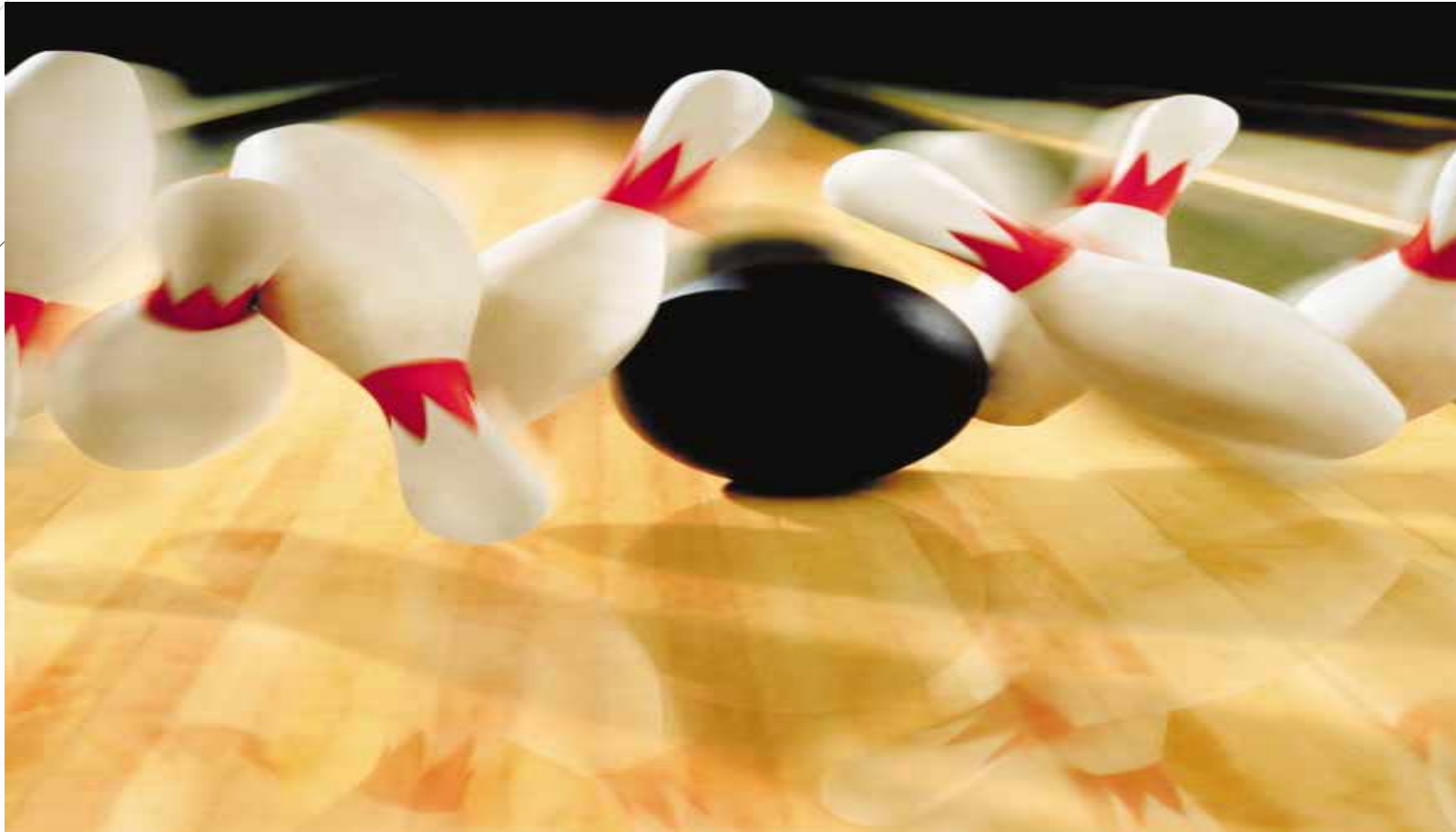

Linear Momentum

- ❑ **Is defined** to be equal to the mass of an object times its velocity.

$$\vec{p} = m\vec{v}$$

- ❑ Momentum is a vector quantity.
- ❑ The vector for linear momentum points in the same direction as the velocity.
- ❑ S.I unit of momentum : Kg . m/s

Linear Momentum

4

The relationship between m & v

- ▶ Huge ship moving at a small velocity

$$P = Mv$$

- ▶ High velocity bullet

$$P = mV$$

Linear Momentum

The relationship between m & v

Example :

- A 10,000 kg truck moving at 2 m/s has a linear momentum of 20,000 kg.m/s ,while a 80 kg bicyclist moving at 2 m/s has a linear momentum of 160 kg m/s.
- ❑ The truck has a much larger linear momentum even though both are moving at the same velocity.
- ❑ It is easier to bring the bicyclist to a stop than it is to bring the truck to a stop.
- Similarly, it is easier to stop a bicyclist moving at 2 m/s than a bicyclist moving at 5 m/s.

Collision & linear momentum

- **The types of collision**
 - Elastic collision
 - Inelastic collision
- **Momentum** of the system is **conserved** in **all collisions**, but kinetic energy of the system is conserved only in **elastic collisions**.

Collision & linear momentum

Another way
to **compare linear momentum**
is to **consider a collision**.

If a boy is running at you at full steam and hits you, you'll probably be knocked down but will still be okay. However, if a truck is coming at you at the same speed and hits you, you will be hurt badly.

In this example, the boy has much less linear momentum than the larger truck.

Conservation of momentum

8

Whenever two or more particles in an isolated system (frictionless, no loss of energy) interact, the total momentum of the system remains constant.

total linear momentum before = total linear momentum after

Linear Momentum and Its Conservation

- If an object's velocity is changing with time, its linear momentum is changing. We have

$$d\mathbf{p}/dt = d(m\mathbf{v})/dt$$

- If the mass of the object is constant then

$$d\mathbf{p}/dt = m d\mathbf{v}/dt = m\mathbf{a}$$

We write

$$d\mathbf{p}/dt = \mathbf{F} = m\mathbf{a}$$

* If the force $F = 0$, That means linear momentum is constant.

- This is a more general statement of **Newton's second law** which also holds for objects whose mass is not constant.

Example : The Archer

10

Let us consider the situation proposed at the beginning of this section. A 60-kg archer stands at rest on frictionless ice and fires a 0.50-kg arrow horizontally at 50 m/s. With what velocity does the archer move across the ice after firing the arrow?



Example : Conservation of momentum

The total horizontal momentum of the system before the arrow is fired is zero ($m_1\mathbf{v}_{1i} + m_2\mathbf{v}_{2i} = 0$), where the archer is particle 1 and the arrow is particle 2. Therefore, the total horizontal momentum after the arrow is fired must be zero; that is,

$$m_1\mathbf{v}_{1f} + m_2\mathbf{v}_{2f} = 0$$

We choose the direction of firing of the arrow as the positive x direction. With $m_1 = 60$ kg, $m_2 = 0.50$ kg, and $\mathbf{v}_{2f} = 50\hat{\mathbf{i}}$ m/s, solving for \mathbf{v}_{1f} , we find the recoil velocity of the archer to be

$$\mathbf{v}_{1f} = -\frac{m_2}{m_1} \mathbf{v}_{2f} = -\left(\frac{0.50 \text{ kg}}{60 \text{ kg}}\right) (50\hat{\mathbf{i}} \text{ m/s}) = -0.42\hat{\mathbf{i}} \text{ m/s}$$

Linear Momentum and Its Conservation

Quick Quiz 9.1 Two objects have equal kinetic energies. How do the magnitudes of their momentum compare?

(a) $p_1 > p_2$

(c) $p_1 < p_2$

(b) $p_1 = p_2$

(d) not enough information to tell.

Linear Momentum and Its Conservation

(d). Two identical objects ($m_1 = m_2$) traveling at the same speed ($v_1 = v_2$) have the same kinetic energies and the same magnitudes of momentum. It also is possible, however, for particular combinations of masses and velocities to satisfy $K_1 = K_2$ but not $p_1 = p_2$. For example, a 1-kg object moving at 2 m/s has the same kinetic energy as a 4-kg object moving at 1 m/s, but the two clearly do not have the same momenta. Because we have no information about masses and speeds, we cannot choose among (a), (b), or (c).



-Elastic Properties of Solids



Elastic Properties of Solids

All objects are deformable when external forces act on it.

That is,

it is possible to change the shape or the size (or both) of an object by applying external forces.

Elastic Properties of Solids

Stress

- is the external force acting on an object per unit cross-sectional area.

$$\text{Stress} = F \ / \ A$$

- is a quantity that is proportional to the force causing a deformation.
- The unit of Stress in SI system is
- The result of a stress is **strain**, which is a measure of the degree of deformation.

Elastic Properties of Solids

- The result of a stress is **strain**, which is a measure of the degree of deformation.
- Strain is proportional to stress. (Strain \propto Stress)
- The constant of proportionality (α) is called **the elastic modulus**.

Elastic Properties of Solids

The types of an elastic modulus :

1. **Young's modulus**, which measures the resistance of a solid to a change in its length.
2. **Shear modulus**, which measures the resistance to motion of the planes within a solid parallel to each other.
3. **Bulk modulus**, which measures the resistance of solids or fluids to changes in their volume.

Elastic Properties of Solids

The elastic modulus:

- Is defined as the ratio of the stress to the resulting: **strain**.
- **Elastic modulus = stress / strain**
- The elastic modulus relates what is done to a solid object (a force is applied) to how that object responds (it deforms to some extent).

Elastic Modulus

1- Young's Modulus: Elasticity in Length

Young's modulus is defined as :

$$Y \equiv \frac{\text{tensile stress}}{\text{tensile strain}} = \frac{F/A}{\Delta L/L_i}$$

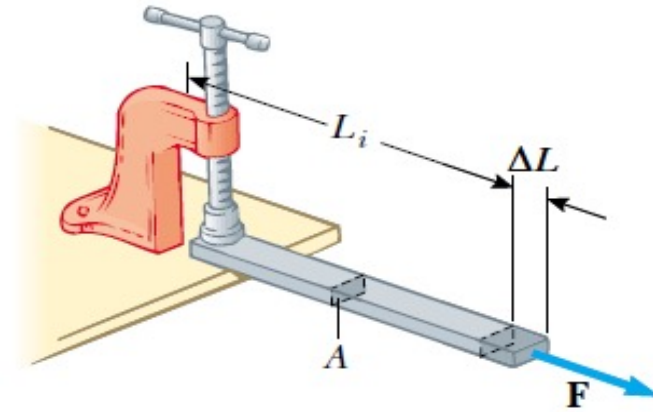

Tensile stress: the ratio of the magnitude of the external force F to the cross-sectional area A .

Tensile strain: in this case the ratio of the change in length ΔL to the original length L_i .

Elastic Modulus

1- Young's Modulus: Elasticity in Length

Young's modulus *is defined as :*

$$Y \equiv \frac{\text{tensile stress}}{\text{tensile strain}} = \frac{F/A}{\Delta L/L_i}$$

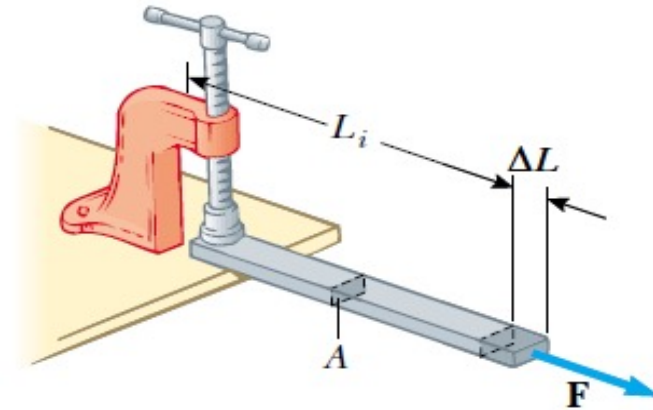

The unit of young 's modulus is the ratio of that for force to that for area. (N \ m²)

1- Young's Modulus: Elasticity in Length

The elastic limit

The **elastic limit** of a substance is defined as the maximum stress that can be applied to the substance before it becomes permanently deformed and does not return to its initial length.

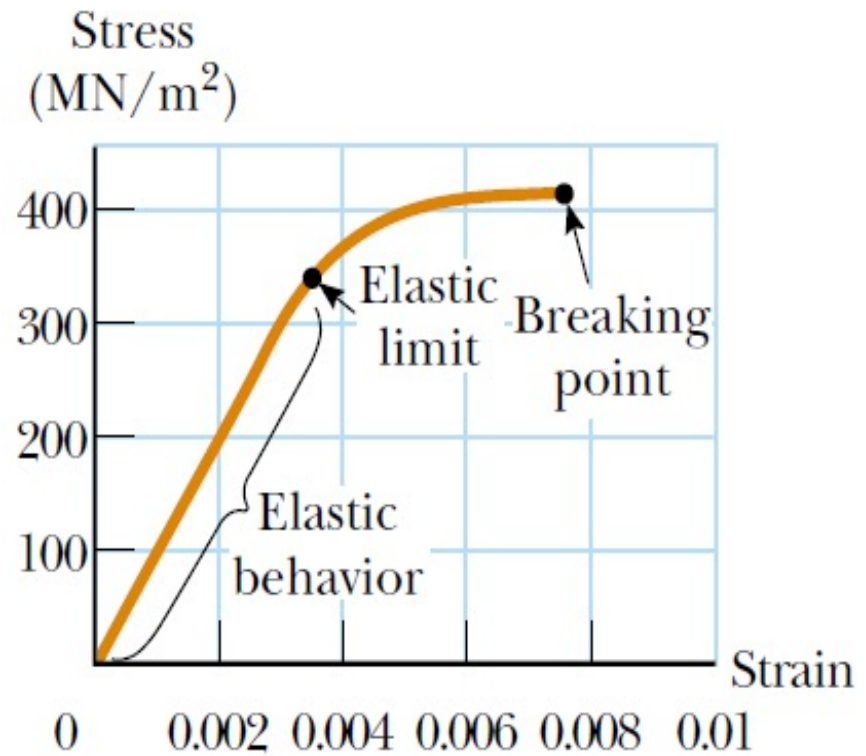

2- Shear Modulus: Elasticity of Shape

Another type of deformation occurs when an object is subjected to a force parallel to one of its faces while the opposite face is held fixed by another force.

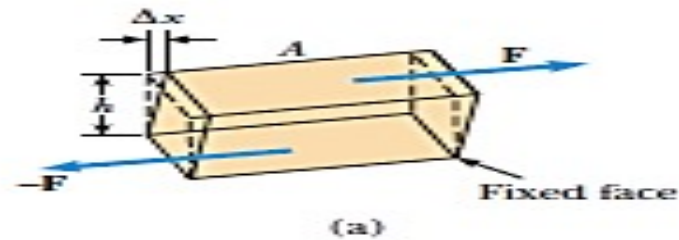

2- Shear Modulus: Elasticity of Shape

$$S \equiv \frac{\text{shear stress}}{\text{shear strain}} = \frac{F/A}{\Delta x/h}$$

Shear stress: ratio of the tangential force to the area A of the face being sheared.

Shear strain: ratio $\Delta x/h$, where Δx is the horizontal distance that the sheared face moves and h is the height of the object.

The unit of shear modulus is
the ratio of that for force to that for area.

3- Bulk Modulus: Volume Elasticity

➤ is defined as:

$$B = \frac{\text{volume stress}}{\text{volume strain}} = -\frac{\Delta F/A}{\Delta V/V_i} = -\frac{\Delta P}{\Delta V/V_i}$$

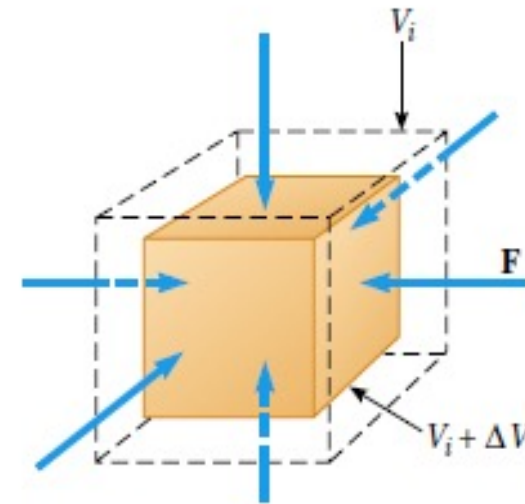

Volume stress: ratio of magnitude of total force F exerted on a surface to the area A of the surface.

$P = F/A$ is called pressure. **If it changes by an amount $\Delta P = \Delta F/A$** , then the object will experience a volume change ΔV .

Volume strain: is equal to the change in volume ΔV divided by the initial volume V_i .



3- Bulk Modulus: Volume Elasticity

- The unit of bulk modulus is the ratio of that for force to that for area.
 - Note that both solids and liquids have a bulk modulus. However, no shear modulus and no Young's modulus are given for fluids. (Why)
- 



3- Bulk Modulus: Volume Elasticity

Answer:

Because a liquid does not sustain a shearing stress or a tensile stress.

If a shearing force or a tensile force is applied to a liquid, the liquid simply flows in response.



Homework

- 1. Can a bullet have the same momentum as a truck? Explain.
- Yes , because $P=mV$ the mass of bullet is small but it has high velocity and the truck has high mass but small velocity so the product may be equal



Homework



- 2- Two materials, A and B, are used to make cables of identical cross section and length, to lift identical loads. If A has a greater Young's Modulus than B, which cable will stretch the most when loaded? Explain why.
- Cable B will stretch the most because it has small young's modulus
- $Y = \frac{F/A}{\Delta L/L}$
- Y is inversely proportion with Δl

